

INSTRUCTIONS

FOR

DISMANTLING AND REASSEMBLING

SHORROCK SUPERCHARGERS

TYPES

C75B, C142B.

SHORROCK SUPERCHARGERS LTD., COVENTRY, ENGLAND.

IMPORTANT

With proper care and servicing in accordance with the instructions sent out with every unit, the Shorrock Supercharger should only require stripping and overhaul after very long periods of running. When complete overhaul is considered necessary, we strongly recommend that the unit be returned to our Distributor or Dealer, who has the experienced personnel and the necessary tools to undertake the work. If this is impossible or if the owner wishes to do the work himself the procedure given herewith should be adopted. At the outset it cannot be too strongly emphasised that the Shorrock Supercharger is a precision mechanism, built to fine limits for efficiency, and undue force may easily cause damage. Throughout the work, cleanliness is of paramount importance.

PRELIMINARY

Remove Supercharger from engine and remove all manifolds, pulleys, pipes and brackets. Remove outrigger housing and shaft, where fitted, by undoing the three nuts securing the housing to the drive end plate. It is convenient to remove the lubricator body from the rear end plate, thus giving a flat surface on which to rest the Supercharger. The lubricator body is removed by undoing the four countersunk head screws holding it to the rear endplate.

IMPORTANT

Before commencing reassembly all parts should be washed in clean petrol (not paraffin) and all traces of grit and dirt removed. The countersunk holes in the two locking plates and the rotor drive plate must be cleaned up with a countersink bit to remove burrs caused by the original locking of the screws.

After cleaning, all ball races, trunnions, vanes, vane shaft and rotor drive plate, must be well oiled with clean engine oil.

All tools and the bench used for reassembly must be scrupulously clean to avoid any dust or dirt entering the supercharger—Remember it is a precision mechanism assembled to fine limits.

When tightening a ring of nuts or screws be sure to tighten evenly to avoid distortion.

After overhaul, particularly if new parts have been fitted, the supercharger should be run-in again in accordance with the servicing instructions.

When ordering new parts, specification number and serial number of supercharger must in all cases be quoted—**this is essential.**

DISMAN

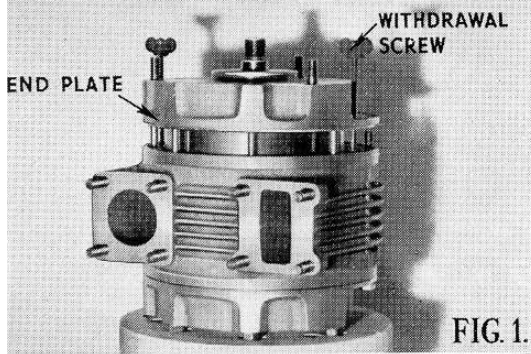

FIG. 1.

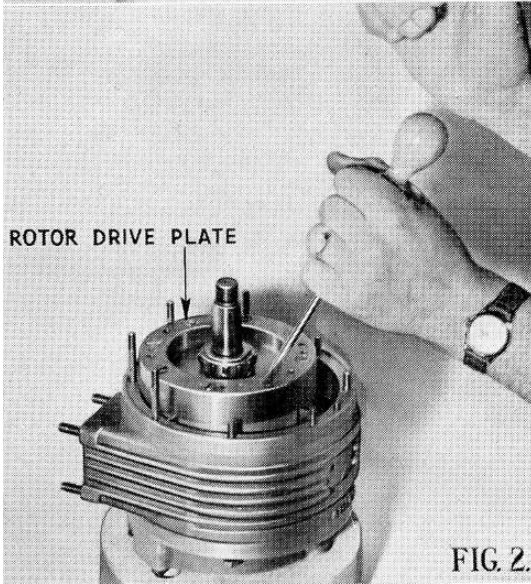

FIG. 2.

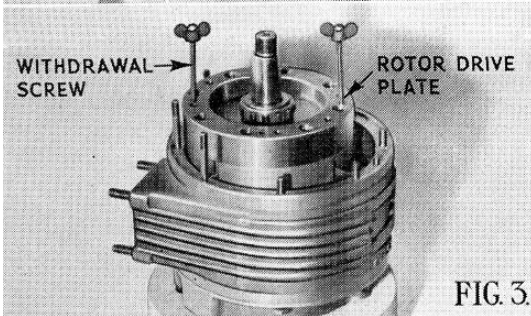

FIG. 3.

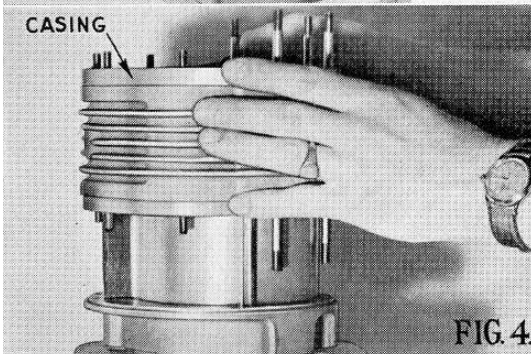

FIG. 4.



FIG. 5.

1. Removal of Drive End Plate.

Undo ring of nuts securing endplate to casing. Remove end plate using two $\frac{3}{16}$ " Whitworth withdrawal screws (Fig. 1), in tapped holes provided. Take care to withdraw end plate squarely.

2. Removal of Rotor Drive Plate

Clear centre-punch depressions in heads of countersunk screws (Fig. 2), securing rotor drive plate to rotor. Remove ring of screws.

3. Remove Rotor Drive Plate, using two $\frac{3}{16}$ " Whitworth withdrawal screws (Fig. 3), in tapped holes provided. Take care to withdraw plate squarely.

4. Removal of Casing.

Undo ring of nuts securing casing to rear endplate. The casing must be taken off squarely (Fig. 4), to avoid damage to vanes and casing bore.

A fairly comprehensive examination can be made at this stage, but should further dismantling prove necessary, proceed as follows:—

5. Remove Vane Shaft Locknut

The nut is locked by a split pin or tab washer. Remove nut, for which special box spanners are available.

NTLING

6. Removal of Vane Assembly.

A special mandrel to the dimensions given further on is essential. Place mandrel against end of vane shaft, invert (Fig. 6) and tap end of mandrel on bench when the vane assembly will slide onto the mandrel on which it should be retained until reassembly, any shims being carefully kept until reassembly. The trunnions will come out with the vane assembly and if removed from the vanes (Fig. 7), should be identified each with its own vane so that on reassembly each trunnion may be replaced on its original vane with all relative bearing surfaces re-positioned as prior to dismantling. Under no circumstances should the vane assembly be dismantled or removed from the mandrel. No attempt should be made to replace one or more vanes or ballraces, as owing to the accuracy and balance required we only supply a new vane assembly complete and do not supply separate parts for this assembly.

7. Removal of Rotor.

Clear the centre-punch depressions in the heads of the countersunk screws securing the locking plate at the bottom of the rotor and remove screws (Fig. 8) and plate. Withdraw rotor complete with ball race (Fig. 9) from rear endplate.

8. Removal of Rotor Ball Race.

Remove countersunk head screws, first clearing screws, and remove locking plate. Remove ball race.

The vaneshaft cannot be separated from the rear end plate. They are locked together for accuracy of alignment and are supplied as a complete assembly, (Fig. 10).

The Supercharger is now completely dismantled.

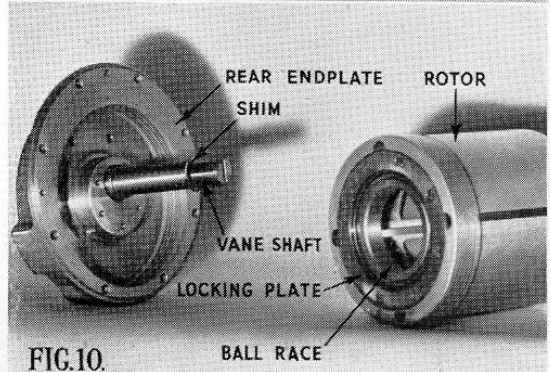
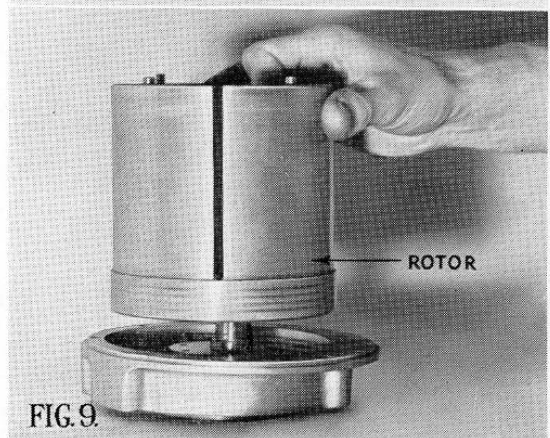
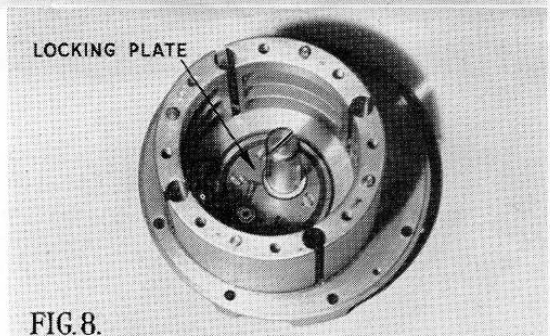
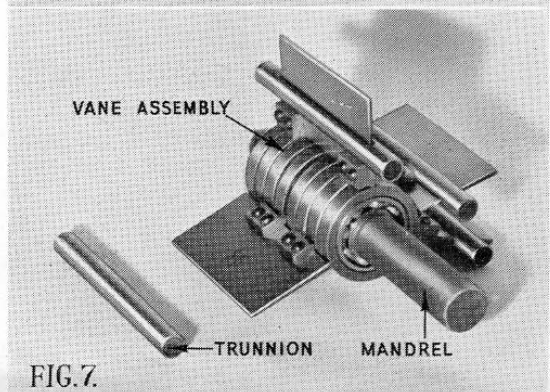
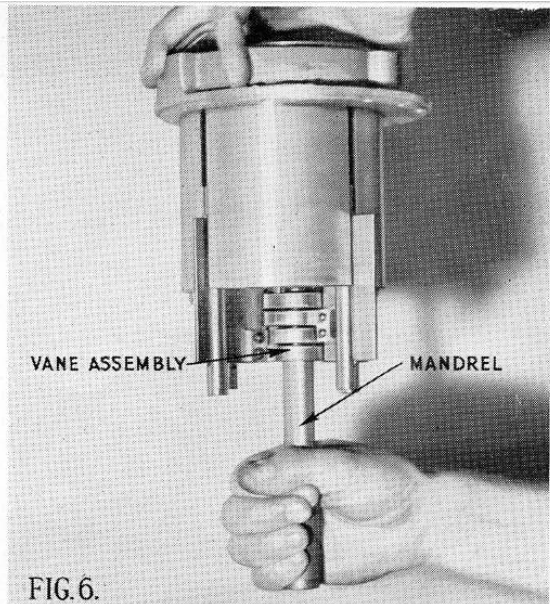

REASSEMBLY

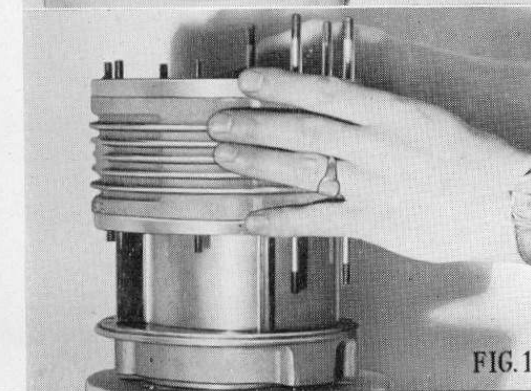
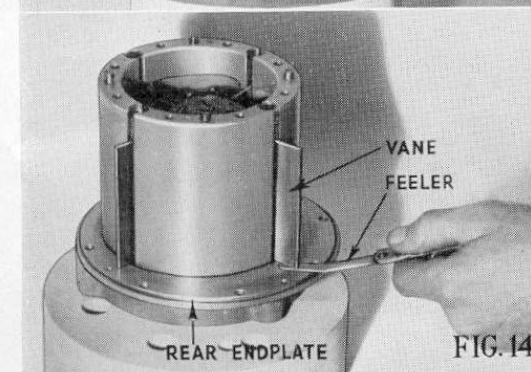
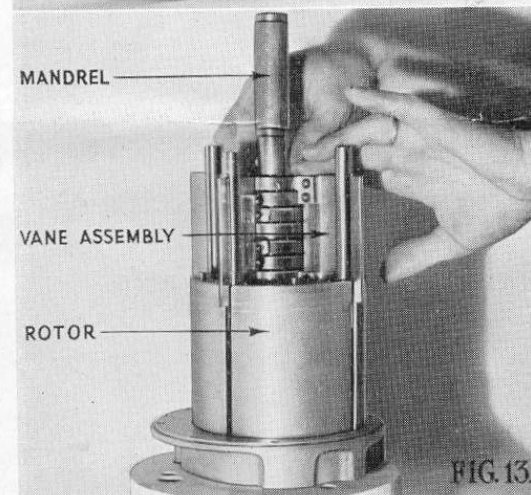
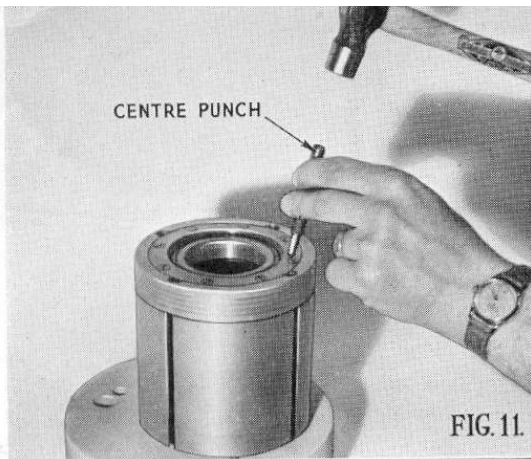

1. Assemble Rotor Ball Race and Rotor Locking Plate.

Be sure to lock all countersunk screws with a centre punch (Fig. 11).

2. Replace Rotor and Locking Plate, locking all countersunk screws (Fig. 12).

3. Replace Vane Assembly & Trunnions, ensuring that the original shims are first placed on the vane shaft (Fig. 13). Replace vane shaft nut and tighten, using special box spanner. Replace split pin or lock tabwasher.

4. Check Vane Clearance between vanes and rear end plate (Fig. 14). The clearance must be between .004" and .006". This may be adjusted by the use of extra shims.

5. Replace Casing.

Care must be taken to ensure that the casing is replaced the correct way round for the rotation required (Fig. 16).

Ensure that the dowel in the casing registers in the end plate, care being taken to replace the casing squarely (Fig. 15), to avoid damage to vanes and casing bore.

1BLING

6. Reversal of Rotation.

Should it be desired to change the Supercharger rotation from clockwise to anti-clockwise rotation or vice-versa looking at the drive end, (Fig. 16) gives the positions of inlet and outlet ports for the two rotations on various casings.

7. Replace Rotor Drive Plate.

This must be replaced squarely (Fig. 17) and register correctly on the four dowels in the rotor. Tighten the ring of counter-sunk head screws evenly and lock (Fig. 11).

8. Replace Drive End Plate (Fig. 18).

Ensure that the casing dowel registers correctly, tighten ring of nuts evenly and replace drive shaft nut and washer.

9. Turn the Drive Shaft gently by hand or with a suitable spanner (Fig. 19).

The Supercharger should turn easily. If it feels stiff or any scraping is audible remove end plate and ascertain cause.

On no account should the Supercharger be run until it revolves freely.

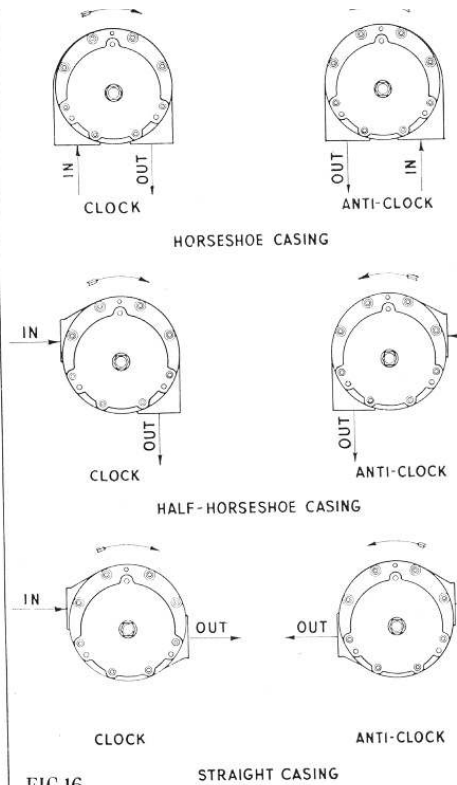

FIG.16.

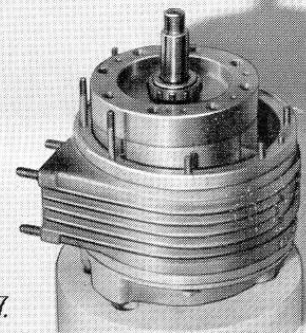

FIG.17.

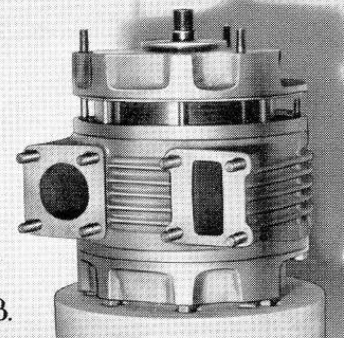

FIG.18.

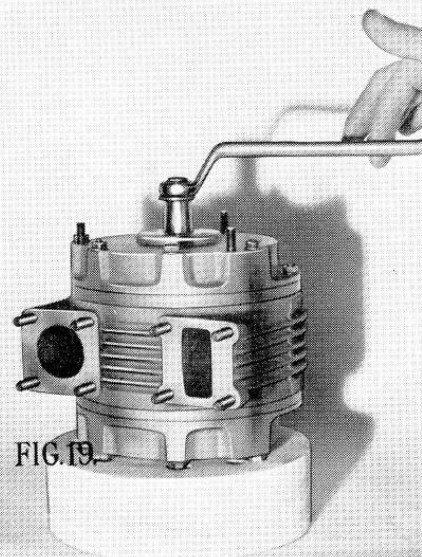

FIG.19.

TOOLS AVAILABLE FOR SHORROCK SUPERCHARGERS

TYPES C75B, CI42B

	C75B	CI42B
Withdrawal Screw	CTL001	CTL001
Tommy Bar for Box Spanner	CTL002	CTL002
Special Box Spanner	CTL003	CTL005
Vane Assembly Mandrel	CTL004	CTL006

These Tools are supplied in sets, packed in suitable boxes.

Sizes of Vane Assembly Mandrels for those who wish to make their own.

The mandrels should have a shoulder at the end of the lengths given below to prevent the vane assembly sliding off the other end. The diameter and length beyond the shoulder being sufficient to allow it to be comfortably held in the hand.

	Dia.	Length to Shoulder
C75B	0.787"—.002" — .004"	4 $\frac{3}{4}$ "
CI42B	0.984"—.002" — .004"	5 $\frac{1}{4}$ "

These diameters should have a ground finish and it will be found convenient to have a lead on the end of about 6° inclusive taper by 1" long.